

»drukodrain plus« type

Compact and exceptionally reliable, level-controlled drain for compressed air condensate. The condensate enters the integrated collecting tank, in which the level is continuously monitored. When the condensate reaches the maximum mark, the pilot valve opens and the condensate is forced into the discharge line by the system pressure. The valve closes again when the level reaches the minimum mark.

Benefits of »drukodrain plus«:

- No pressure loss
- Diaphragm protected by integrated cup filter
- Test button for manual outlet
- Auto-reset function
- Suitable for all condensate types

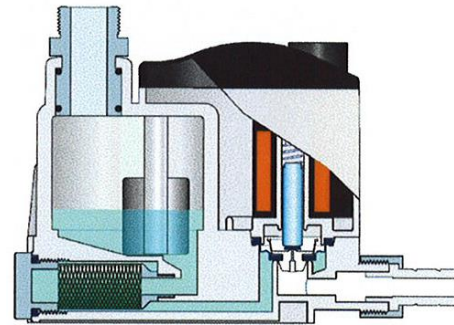

Compressor capacity:	10 m ³ /min
Dryer capacity:	20 m ³ /min
Filter capacity:	100 m ³ /min
Voltage:	230 VAC / 50 Hz
Working temperature:	+1 °C to +60 °C
Weight:	350 g
Connection thread:	Input 1/2" outside
	Output hose connector 10 mm inside
Protection IP:	IP 65

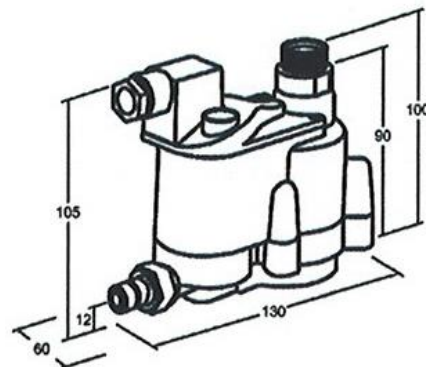

»drukodrain plus« drain for compressed air condensate

Art. No.	Ident No.	Operating pressure
KA 20	101626	0,2 to 16 bar

- ⇒ The following voltages on request:
24 VDC, 24 VAC DC, 24 VAC / 50 Hz, 110 VAC / 50 Hz, 115 V / 50 Hz